

# Isolation and Molecular Characterization of Cellulolytic Microbes From Cow Dung

Puja Jhunjhunwala Chahar, Alka Prakash\*

Department of Zoology, Faculty of Science, Dayalbagh Education Institute, Agra

## Abstract

Cow dung, a potent fuel and fertilizer source also acts as a source of cellulose degrading microbes. Cellulose, the most abundant polymer in nature is a linear polysaccharide of up to 15000 D-glucose residues having  $\beta$  (1-4) glycosidic linkage. It forms the major component of the lignocellulosic biomass which is the main part of the ruminants' diet. The enzyme cellulase breaks down the cellulose to smaller products. In the present study, 25 isolates were obtained from cow dung samples employing cellulose containing media. All the isolates were analyzed for cellulose degrading activity using the Congo Red Assay and were screened for exonuclease and endonuclease enzyme activity. These were further subjected to the RAPD analysis.

**Keywords:** Cellulase, Cellulose, Congo Red Assay, Cow dung, RAPD

## Introduction

Cow dung is excreted by the herbivorous bovine species. Besides being a fuel source, it also acts as a purifier, disinfectant, organic fertilizer and more recently as a source of cellulose degrading microbes (Girija *et al.*, 2013).

Cellulose is the most abundant polymer in nature. It is a linear polysaccharide of up to 15000 D-glucose residues having  $\beta$  (1-4) glycosidic linkage. Cellulose is broken down by the enzyme cellulase (EC 3.2.1.4), which is classified into three main types: endoglucanases which disrupt the crystalline structure of cellulose by breaking it at random sites and create free chain ends, exoglucanases which attack exposed chain ends and thus release cellobiose from free ends; and  $\beta$ -glucosidase which finally convert the cellobiose units to glucose (Karigar and Rao, 2011).

Cellulase finds applications in various industries like-textile (bio polishing of fabrics to produce stonewashed looks of denims), detergent (to improve fabric softness and brightness), food (to improve quality of animal feeds and juices) and paper and pulp (de-inking of paper). Its most important and emerging application are of decomposition of several types of cellulosic biomass (Khan *et al.*, 2011; Kuhad *et al.*, 2011). The various types of biomass wastes such as wood, agricultural wastes like rice husk, industrial wastes like paper pulp, municipal solid waste and energy crops act as good substrates for decomposition and produce useful by-products like ethanol (Kumar and Singh, 2009).

The application of molecular typing method in contrast to the uncertainties of phenotypic characterization can provide a stable and discriminatory molecular characterization of bacterial isolates. Randomly Amplified Polymorphic DNA (RAPD) is a PCR technique to detect nucleotide sequence polymorphisms using single primer of arbitrary nucleotide sequence (8-12 nucleotides) which anneals to different locations in the genome producing a pattern of amplified products, i.e., 'fingerprint pattern' specific to a template DNA (Shalini *et al.*, 2007). Thus this technique offers reliable method of characterization of diversity among different species, identify the breeds, variation among population and intra-specific genetic variability at molecular level (Kumari and Thakur, 2014).

The present analysis was conducted to detect and characterize the microbes that degrade cellulose.

## Materials and Methods

### Sample Collection

Four cow dung samples were collected from different areas of Agra district, in sterile 50 ml Tarson tubes, with the help of clean sterile slides. The samples were then stored at 4°C until further use.

### Isolation of Cellulolytic Bacteria

0.5 g of each sample was suspended in 5 ml of nutrient broth for initial enrichment followed by a serial dilution. 0.2 ml of aliquot of each dilution was spread on the

cellulose containing minimal media plates and incubated for 48 hours at 37°C (Corcoran *et al.*, 2008; Das and Qin, 2012). Isolates thus obtained were then maintained on nutrient agar slants for further processing.

### Screening of Cellulolytic Bacteria

The isolates were then screened using Congo Red Assay on two types of Congo red media (Gupta *et al.*, 2012), one containing cellulose powder (insoluble) and the other containing CMC (carboxy methyl cellulose- soluble) as the substrate to ascertain the production of Exoglucanase and endoglucanase, respectively (Sadhu and Maiti, 2013). The cellulase produced by the microbes digests the cellulose in the media and thus the dye is unable to bind to the area from where cellulose is digested and this area shows clear zones.

### Genomic DNA Extraction

Genomic DNA of the isolates was extracted by the boiling and centrifugation method (Elkhalil *et al.*, 2015). The isolates were inoculated in 3ml of nutrient broth. 1ml of the broth was transferred in microfuge tube and was then given 3-4 min spin to obtain cell pellets from the broth. The supernatant was discarded; the pellets were suspended in 500µl of sterile distilled water and given a spin again for 3-4 minutes. The supernatant was again discarded and the pellet was re-suspended in 200µl of sterile distilled water and then subjected to boiling water bath for 10 minutes followed by incubation in ice for 15-20 minutes. It was again given a spin of 2-3 minutes to sediment cell debris and the supernatant containing the DNA was carefully transferred to another microfuge tube and stored at 4°C. The DNA concentration and purity was checked by spectrophotometer analysis at 260 nm and 280 nm (Sambrook *et al.*, 1989; Aidar and Line, 2007).

### RAPD-PCR Amplification

The DNA amplification was performed employing OPA11 primer (5'CAATCGCCGT3') (Baker *et al.*, 2002) using Applied Biosystem 2720 thermocycler. 10 µl reaction consisting of 1X reaction Buffer F, 1.5 mM MgCl<sub>2</sub>, 0.4 mM dNTP mix, 1 µM of primer, 0.05U/µl of Taq polymerase and approximately 10 ng of genomic DNA was used for DNA amplification. The thermal cycle used for the RAPD amplification was as follows -initial denaturation at 94°C for 5 minutes, followed by 45 cycles of 94°C for 1minute, 32°C for 1 minute, 72°C for 2 minutes and final extension at 72°C for 8 minutes. The PCR products were resolved on 1.5% agarose gel by electrophoresis in 1X TAE buffer at 75 volts for 50 minutes along with 100bp ladder. Gels were stained with Ethidium bromide dye and were thus visualized under UV Gel Doc and photographed using high resolution camera (Shalini *et al.*, 2007).

## Results and Discussion

Cow dung acts as a good source of cellulase producing microbes which convert the wastes into useful byproducts (Khan *et al.*, 2011). Das and Qin, (2012) utilized such microbes as feed additives for ruminants and Corcoran *et al.*, (2008) used them for ethanol production from wastes. In the present work, 85 cellulose degrading isolates were obtained from the cow dung samples cultured on the selective minimal media.

Congo red in the media acts as an indicator for cellulose degradation as it is unable to form a coloured complex with degraded cellulose, but forms clear zones around the colonies and thus presents a sensitive and rapid method for screening of cellulolytic bacteria (Gupta *et al.*, 2012). Of the 85 isolates, 25 isolates show clear zones and exhibit cellulolytic activity after 24 hours incubation and were thus selected for further studies. Of these, 18 isolates were from cow dung Sample I, 2 isolates from Sample II, 3 isolates from Sample III and 2 isolates from sample IV.

The ability of the microbes to produce endoglucanase and exoglucanase was determined through the two types of Congo Red Assay. Cellulose degradation was exhibited by the isolates on the plates containing different types of cellulose, that is, soluble carboxy-methyl cellulose (Fig. 1a) and insoluble cellulose (Fig. 1b), indicating the type of

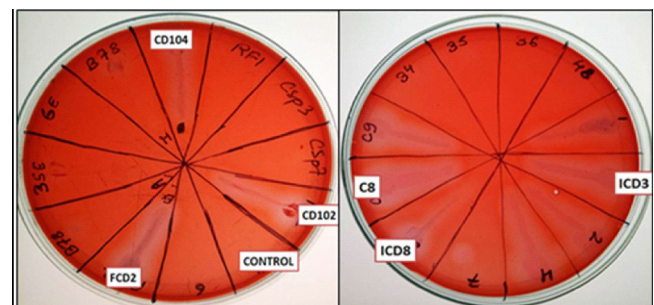

Fig.1(a). Screening isolates on Congo Red Media containing Carboxy Methyl Cellulose (CMC-soluble) as substrate.

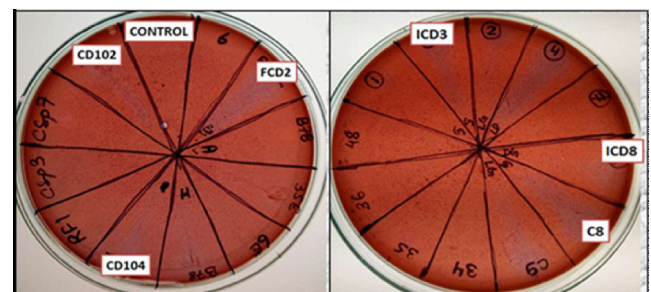

Fig.1(b). Screening of isolates on Congo Red Media containing Cellulose Powder (Cellulose-insoluble) as substrate

enzyme being produced. Endoglucanases cut at random sites in a cellulose polysaccharide and thus are active against acid swollen amorphous or soluble derivatives of cellulose such as CMC whereas exoglucanases cut at the ends of the chains liberating cellobiose, and are active against amorphous insoluble cellulose (Sadhu and Maiti, 2013). In the present study, 20 isolates degrade both types of substrates, and exhibited distinct hydrolyzing capacity on these Congo Red media.

The Boiling-Centrifugation Method though is a simple and easy method of DNA extraction but usually yields DNA with protein contamination (Aidar and Line, 2007). According to Shalini *et al.*, (2007) DNA concentration needs to be determined because higher concentration of DNA leads to higher background and interferes with the amplification whereas lower concentration does not supports the amplification. An optimal DNA concentration prevents variability in RAPD profiles. The genomic DNA yield as measured spectrophotometrically at 260 nm was between 0.08 µg/µl to 1.8 µg/µl. Thus the final concentration of the DNA in the PCR reaction mixture was 0.2 µg/µl. The 260 nm: 280 nm ratios were always less than 1.8 indicating protein contamination.

In RAPD technique, random amplification of different loci of the entire genome produces a fingerprint pattern specific to a particular species (Elkhalil *et al.*, 2015). Baker *et al.*, (2002) state that the fingerprint pattern obtained is due to the amplification by employing an arbitrary primer which binds at random sites and also due to the non-specific binding of the primer to the genome due to low annealing temperature. The OPA-11 primer used is expected to bind every  $4^{10}$  bases in the genome (Baker *et al.*, 2002). A dendrogram was generated from the RAPD fingerprint obtained. Genetic variability was observed among the 20 isolates generating 6 different types of RAPD profiles. Fig. 2 shows the RAPD profile of isolates obtained from cow dung samples employing OPA11 primer. Dendrogram analysis (Fig. 3) of the RAPD profile, done with the help of Total Lab Quant v12.2 software, revealed three major clusters. The first cluster with genetic distance 0.002 showed two sub clusters of isolates C8 (G.D. - -0.002) and FCD2 (G.D. - 0.113). This revealed that the two isolates share common ancestry but have diverged with time into two different types of microbes. The second cluster with genetic distance -0.002 showed that the isolate ICD8 was different compared to other isolates. The third cluster with genetic distance of 0.041 is the most evolved and diverged group, where there were two sub clusters. In the first sub cluster with 0.139 genetic distance, the two isolates ICD9

and ICD3 shared similar distances of 0.03 thus can be considered as same species without much divergence to consider them as different species. In the second sub cluster with genetic distance - 0.105, the two isolates CD102 (G.D. - 0.158) and CD104 (G.D. - 0.042) also shared common ancestor but their genetic distance and RAPD profile indicate that they have diverged as two different microbes. Thus 6 varied profiles were obtained from RAPD molecular typing of the isolates.

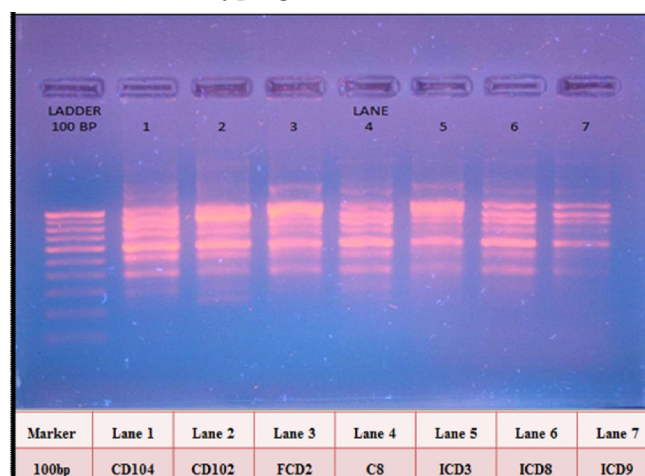

Fig.2. RAPD profile of isolates obtained from cow dung with OPA11 primer

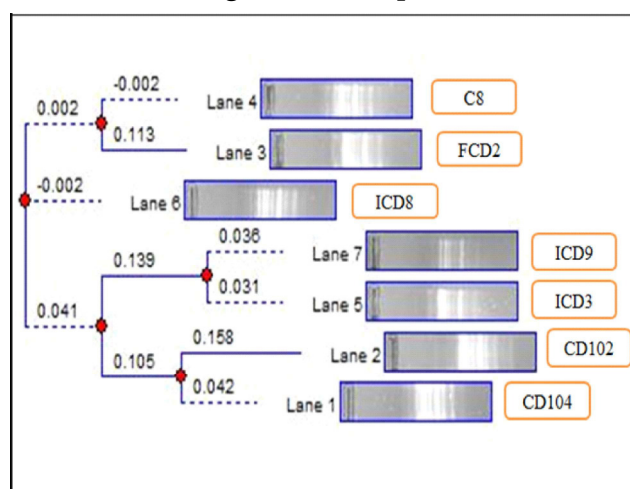

Fig.3 : Dendrogram showing Genetic diversity among seven isolates of which 6 were found to be unique based on the genetic distances obtained from the RAPD profile

Thus the 6 isolates - CD104, CD102, FCD2, C8, ICD3, and ICD8 from cow dung samples show a potential to degrade cellulose in different forms and could be used for various applications. This study can be translated to large scale degradation of cellulosic biomass.

## Acknowledgement

I would like to acknowledge Cell Biotechnology Lab, Department of Zoology, Faculty of Science, Dayalbagh Education Institute, for providing the required facilities and CSIR for providing me funds, for my work.

## References

- Aidar, M., Line, S. R. P. (2007) A Simple and Cost-Effective Protocol for DNA Isolation from Buccal Epithelial Cells. *Braz Dent J* **18**(2): 148-152.
- Baker, J. C., Crumley, R. E., Eckdahl, T. T. (2002) Random Amplified Polymorphic DNA PCR in the Microbiology. *Biochem Mol Biol Educ* **30**(6): 394-397.
- Corcoran, B. A., Henry, J. C., Rice, R. R., Rismani-yazdi, H. D., and Christy, A. D. (2008) Cellulosic Ethanol from Sugarcane Bagasse Using Rumen Microorganisms. *An ASABE Meeting Presentation*: **300**(8).
- Das, K.C., Qin, W. (2012) Isolation and characterization of superior rumen bacteria of cattle (*Bostaurus*) and potential application in animal feed stuff. *Open J Anim Sci* **2**(4): 224-228.
- Elkhalil, E. A. I., Gaffar, F. Y., El Siddig, M. A., Osman, H. A. H. (2015) Isolation and Molecular Characterization of Cellulolytic Bacillus Isolates from Soil and Compost. *AJMR* **3**(2): 55-58.
- Girija, D., Deepa, K., Xavier, F., Antony, I., Shidhi, P. R. (2013) Analysis of cow dung microbiota – A metagenomic approach. *Indian J Biotechnol* **12**: 372-378.
- Gupta, P., Samant, K., Sahu, A. (2012) Isolation of Cellulose-Degrading Bacteria and Determination of Their Cellulolytic Potential. *Int J of Microbiol* doi:10.1155/2012/578925.
- Karigar, C. S., Rao, S. S. (2011) Role of Microbial Enzymes in the Bioremediation of Pollutants/: A Review. *SAGE-Hindawi, Enzyme Research* doi:10.4061/2011/805187.
- Khan, J. A., Ranjan, R. K., Rathod, V., Gautam, P. (2011) Deciphering Cow Dung for Cellulase Producing Bacteria. *Eur J Exp Biol* **1**(1): 139-147.
- Kuhad, R. C., Gupta, R., Singh, A. (2011) Microbial Cellulases and Their Industrial Applications. *SAGE-Hindawi Access to Res Enzym Res* doi:10.4061/2011/280696
- Kumar, S., Singh, S. P. (2009) Recent Advances in Production of Bioethanol from Lignocellulosic Biomass. *Chem Eng Technol* **32**(4): 517-526.
- Kumari, N., Thakur, S. K. (2014) Randomly Amplified Polymorphic DNA-A Brief Review. *Am J Anim Vet Sci* **9**(1): 6-13.
- Sadhu, S., Maiti, T.K. (2013) Cellulase Production by Bacteria: A Review. *British Microbiol Res J* **3**(3): 235-258.
- Sambrook, J., Fritch, E.F., Maniatis, T. (1989) Molecular Cloning, a laboratory manual, 2<sup>nd</sup> edition. Cold Spring Harbor Laboratory Press, New York.
- Shalini, Tiwari, S., Gupta, R.K., Pabbi, S., Dhar, D.W. (2007) Protocol Optimisation for RAPD in Cyanobacteria. *Indian J Biotechnol* **6**: 549-552.